

Teleoperation of Field Mobile Manipulator with Wearable Haptic-based Multi-Modal User Interface and Its Application to Explosive Ordnance Disposal

Dongseok Ryu

*Intelligent Robotics Research Center, Korea Institute of Science and Technology, Seoul, Korea
Department of Mechanical Engineering, Korea University, Seoul, Korea*

Chang-Soon Hwang

*Intelligent Robotics Research Center,
Korea Institute of Science and Technology, Seoul, Korea*

Sungchul Kang*

*Intelligent Robotics Research Center,
Korea Institute of Science and Technology, Seoul, Korea*

Munsang Kim

*Intelligent Robotics Research Center,
Korea Institute of Science and Technology, Seoul, Korea*

Jae-Bok Song

*Department of Mechanical Engineering,
Korea University, Seoul, Korea*

This paper describes a wearable multi-modal user interface design and its implementation for a teleoperated field robot system. Recently some teleoperated field robots are employed for hazard environment applications (e.g. rescue, explosive ordnance disposal, security). To complete these missions in outdoor environment, the robot system must have appropriate functions, accuracy and reliability. However, the more functions it has, the more difficulties occur in operation of the functions. To cope up with this problem, an effective user interface should be developed. Furthermore, the user interface is needed to be wearable for portability and prompt action. This research starts at the question: how to teleoperate the complicated slave robot easily. The main challenge is to make a simple and intuitive user interface with a wearable shape and size. This research provides multi-modalities such as visual, auditory and haptic sense. It enables an operator to control every functions of a field robot more intuitively. As a result, an EOD (explosive ordnance disposal) demonstration is conducted to verify the validity of the proposed wearable multi-modal user interface.

Key Words: Wearable Device, Multi-modal Interface, Field Robot, Teleoperation, Haptics

1. Introduction

For the past decades, several field robots have been developed (<http://www.irobot.com/>; <http://www.remotec-andros.com/>; <http://www.highcom-security.com/>; Penny et al., 2002). It is designed to take the place of human in dangerous work, such

* Corresponding Author,
E-mail : kasch@kist.re.kr
TEL : +82-2-958-5589; FAX : +82-2-958-5629
Intelligent Robotics Research Center, Korea Institute of Science and Technology, Seoul, Korea. (Manuscript Received November 16, 2004; Revised August 24, 2005)

as rescue tasks in disaster, patrol works in airport, even missions in war places. The final goal of a field robot system is to accomplish these missions autonomously with its own intelligence. Unfortunately, it is beyond the state of the art, and human intervention is still needed. Therefore, most of the developed field robot systems adopt teleoperation control scheme.

Basically, a field robot must have appropriate performances enough to complete given missions. Therefore, the performances of the robot, such as accuracy, reliability, dexterity and various sensing ability, are mainly focused in developing the system. To meet this requirement, remarkable improvement has been achieved to make the slave robot. Recent field robots install various sensors (e.g. vision, sonar sensor, inclinometer, etc.) to gather environment information, and they have adequate mechanisms for manipulation and mobility.

However, the more functions the slave has, the more difficulties it may have to operate the slave in teleoperation control. The dexterous motion usually requires complicated command sets in operation. The more information is gathered, the more confusion comes to the user. How to present information clearly to the operator is as important as how much information to be gathered. In developing a field robot system, therefore, it becomes a more serious problem to design the user interface of the teleoperation system. As long as teleoperation concept is applied, not only to design the slave robot but also to make a smart user interface should be considered as an essential technology.

The user interface carries out two functions: to command the robot, and to feedback the situation of the robot to the operator. For the command, most existing field robots use a joystick-type device, and the number of its degrees of freedom is too less to control all joints at a time (Penny et al., 2002; Takahashi and Masuda, 1992). Furthermore, many of field robot systems control the slave not in the Cartesian space but in the joint space, using their joystick-type input device. For the feedback, main view monitor and a few auxiliary indicators are used. Therefore, the dispers-

ed indicators cause inattentiveness and the user cannot grasp the situation immediately. For this problem, not only vision sense but also various human senses (i.e. visual, auditory and haptic sense) should be used. Both command and feedback functions should be simple and intuitive in order to draw the operator's attention on a given mission. To handle this problem, a multi-modal approach has been introduced as one solution for HRI (human and robot interface) and HCI (human computer interface) application (Nonami and Shimoi, 2000; MacGuire et al., 2002; Iba et al., 2002; Ghidary et al., 2001; Ryu et al., 2004).

Besides, a portability of a system raises one of the serious designing issues, because the portable user interface is appropriate for outdoor teleoperation control. As small and effective slaves have been developing, a portable user interface would be demanded. Therefore, a small, light-weight and rugged user interface device is strongly needed.

In this research, using a multi-modal interaction method, a simple and intuitive command method for a field robot is proposed, as shown in Fig. 1, and its detailed control method is described. The remainder of this paper is organized as follows. In section 2, design of a proposed user interface is introduced. Section 3 deals with an integration of a field robot system. Section 4 describes semi-autonomous features and control

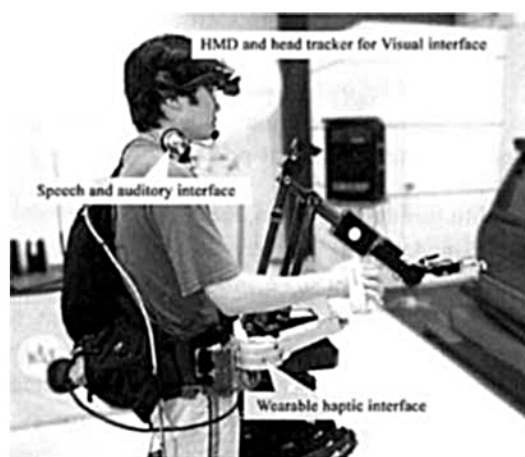

Fig. 1 Appearance of proposed wearable multi-modal user interface

methodology. Section V shows experiment, and section 5 concludes the research results.

2. Wearable Multi-modal User Interface

In the teleoperated field robot system, the robot is designed to be a faithful slave to face with the dangerous environment, while the operator using a user interface manages the slave in the safe site from a distance. The features of the user interface are classified as follows.

- (1) Command to the robot
- (2) Feedback the situation of the robot to the user.

Ideally, the design goal of a user interface is to make it transparent, as the user feels as if he or she works in the actual spot of the slave. To achieve this transparency, actual design issues are raised as follows :

- (1) Simplicity :
 - All indicators are unified as one scene.
 - All input button and joystick are integrated into one haptic device.
- (2) Intuitiveness :
 - High-level command by speech recognition.
 - Human friendly feedback such as graphs indicator, human voice.
 - Motion command matching between the haptic device and the slave in Cartesian space.
- (3) Portability :
 - Carried by one person.
 - Standalone operation without communication lines and additional power.

With this design factors, the proposed wearable multi-modal user interface has been developed and integrated as shown in Fig. 1. The operator wears the HMD, head tracker and headset to interact with the slave. A six degree-of-freedom haptic master is attached on his waist together with the standalone controller, and the operator grips its handle to tele-manipulate in Cartesian space.

All control hardware with batteries are pack-

ed into one backpack, so that the user can work around in teleoperation. It includes RF and wireless LAN modules enabling completely wireless communication. It is composed of three major interfaces. Following subsections describe how they work.

2.1 Speech and auditory interface

In this research, the operator sends two types of commands to the robot. The one is a selection command and the other is a continuous motion command. For example, the selection between navigation and manipulation mode, the reset of the robot arm and mobile base, the on/off and reset of pan-tilt motors, the speed selection of the mobile, the selection among installed cameras are defined in the selection commands. These commands are executed through the speech recognition. When the operator says a word which has been predefined as a command, the speech interface can be aware of the word. If the speech recognition system successfully recognizes what he says, the recognized command pops up on the HMD for confirmation. Finally, the operator would decide to execute or cancel the command with the confirmation button on the haptic master.

The auditory interface synthesizes the human voice by an installed speech synthesis engine. It can warn of the approach of obstacle by sound, or inform of the relative position of a pointed object by a laser displacement sensor mounted in the slave.

2.2 Wearable haptic interface

A new lightweight wearable haptic device is developed, as shown in Fig. 2. The base linkage is designed as a serial RRP mechanism to measure a translation, and a RRR z-y-z rotation mechanism is attached at the end of the base linkage for rotation.

The prismatic joint, the third joint in the base mechanism is composed of three pieces of links that slide into each other as shown Fig. 3. The sliding links design makes the device compact in folded configuration, and also it makes large workspace when it extends.

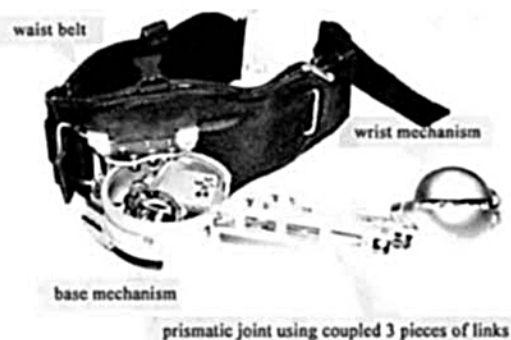

Fig. 2 Picture of developed wearable haptic device

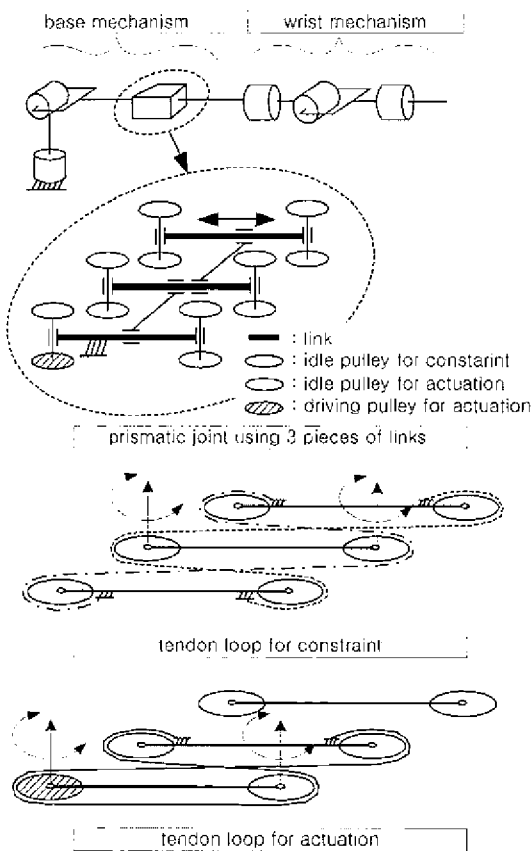

Fig. 3 Prismatic joint with coupled 3 pieces of links and tendon loops

To achieve a compact design and reduce its weight, a novel tendon driven mechanism is designed at each joint. Particularly, the three sliding links has pulleys on each end and two tendon loops are built in the prismatic joint. as shown in Fig. 3. The one is for making constraint and

Table 1 Specification of Wearable haptic device

Degree of freedom	6 (3) ^a
Max continuous feedback force	10 N
Workspace	550 mm hemisphere
Weight	2.2 kg (3.8 Kg) ^b
Operation time	1.5 hour

a for force feed back

b Including standalone controller and battery

the other is for actuation. The three sliding links are kinematically coupled by tendon. Consequently, the three links moves like a one degree-of-freedom prismatic joint.

Due to weight constraints, only 3 actuators are installed for force feedback, and each actuator is specially designed to fit the joint. Because a passive actuator is better than an active actuator with respect to power density (power per unit volume or weight), small MR (Magneto-rheological) brakes have been developed. It is installed at each joint of the base linkage for force feedback. Also a compact brake drive with current feedback capability has been designed which enables to reduce the response time of the MR brake. In tele-manipulation, the user can use whole 6 degrees of freedom as an input device, while 3 degree-of-freedom force feedback is performed.

The controller is packed into a bag which is attached on back side of waist. Because it includes a brake driver module, a satellite controller, a wireless LAN module and a battery, it can perfectly operate alone. The specification of the haptic master is summarized as shown Table 1.

2.3 Visual interface

The visual interface shows the robot's view, the status of sensed data, and the status of speech commands. Since the slave equips a stereoscopic camera, the user sees three-dimensional view on the HMD. The operator wears the head tracker and it generates a pan/tilt command from the 2-dof head motion. In the integrated system, it is used for the command of moving the direction of installed camera, thus the user can easily look around the environment of the robot, as shown in Fig. 4(a).

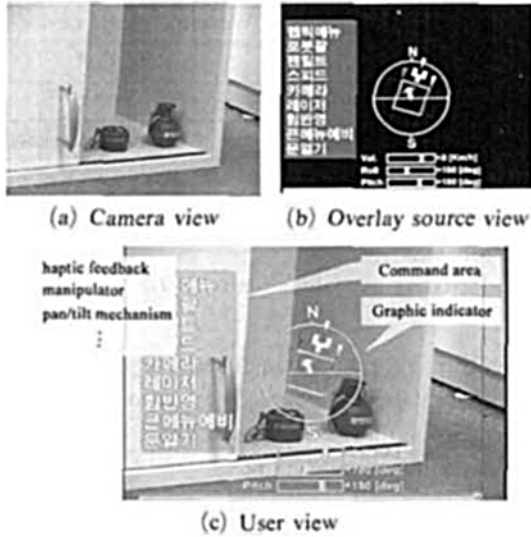

Fig. 4 Appearance of integrated visual interface

Moreover, the head tracker is useful to indicate an object as a target. The operator moves his head and looks at a target to get an information of direction and distance, then trig a laser displacement sensor which is placed in parallel with the pan/tilt camera. The vision information is sent via a RF channel while the sensed data is feedback via an independent wireless LAN channel to reduce the traffic in data communication. A source for video overlay is prepared with the reported data, as shown Fig. 4(b). The recognized speech command is highlighted on left side to confirm. When an obstacle is detected by ultrasonic sensor, it shows around robot icon in the middle of the scene. Other useful and important information (i.e. velocity, heading direction, view direction, arm posture and etc.) are shown by bar graphs. It is overlaid on the remote video source pictures and unified to single scene. Finally the operator sees the stereoscopic picture and the status of the robot at a glance immersivly on the HMD. The overlaid view is shown in Fig. 4(c).

3. System Integration and Control

3.1 Integration of a field robot system

To examine the proposed interface, using the ROBHAZ-DT2 as a slave, the field robot system is integrated (Kang et al., 2003). The ROBHAZ-



Fig. 5 Integrated field robot system: teleoperator with multi-modal interface and ROBHAZ-DT2

DT2, which was developed as a teleoperated mobile manipulator for hazard environment applications. A mobile base is designed to get high adaptability to uneven terrain using passive double tracks, and a manipulator is equipped on the mobile base. The robot has totally nine degrees of freedom, thus it can move in a hazard environment, and also dexterous manipulation can be performed. A stereoscopic camera, ultrasonic sensors, inclinometers and joint-torque sensor on each joint gather the environmental information. With the proposed user interface, the integrated system is shown in Fig. 5.

3.2 Semi-autonomous feature

While the user carries out a mission by tele-manipulating a field robot, it can be classified two tasks. The one is to move the mobile base, and the other is to operate the manipulator. For this reason, the operation modes are mainly di-

vided a navigation mode and a manipulation mode, and the user selects the modes by speech. When the navigation mode is selected, the user can drive the mobile base by moving the knob of the haptic master. On the contrary the manipulator is operated by the whole motion of the master in the manipulation mode.

A given mission is generally composed of several operation processes, and they commonly include three stages: approaching, manipulating and returning process. When the mission starts, the user should move the slave close to the object within the reach of its manipulator. It is the first stage: approaching. After the mobile base reaches in the vicinity of the target, the user changes the mode from navigation to manipulation mode. When the mission is completed, the slave would go back to a safe area.

In many cases, approaching and returning processes would be tedious work, and manual control may not be essential. If it is possible, it would be more efficient to move autonomously rather than to devote to operating manually every step of moving. For the manipulation process, it would be dangerous if we fully resort to only autonomous manner, even though the autonomous function is needed.

In the robot system, therefore, a target approaching feature and a compliance control are integrated as semi-autonomous features to help the operator. The target approaching feature can help the user easily move near the object, when he/she is searching around and preparing next work in

the same time. The detailed method is that once the user firstly finds an object via the HMD, then the user would assign it as a target using laser displacement sensor. After the object is targeted, information of the direction and distance is provided by speech. If the user commands to move to the predefined object, the slave autonomously locally controls its velocity and position using odometry to approach autonomously near the object. Compliance control is applied to manipulation tasks. Not only it can protect the manipulator from the contact with environment by improper command or unexpected contact, but also it is adequate for some dexterous tasks (e.g. opening door, writing on the board, wall scratch).

3.3 Control of integrated system

Basically, a tele-manipulation system can be simply modeled using two-port networks theory, as shown in Fig. 6.

A master system can be represented as a node in left side, and they exchange the parameters, such as the velocity or position vector \dot{x}_m , \dot{x}_s and the force F_m , F_s at each node.

The human operator grips the handle of the master device, and the master controller calculates the position and velocities and sends the parameters to the slave in the right side. The controller in slave robot controls the manipulator with respect to the transmitted reference position and velocities. An error between the master and slave can occur due to a limitation of mechanical bandwidth or an interruption of an obstacle. In that

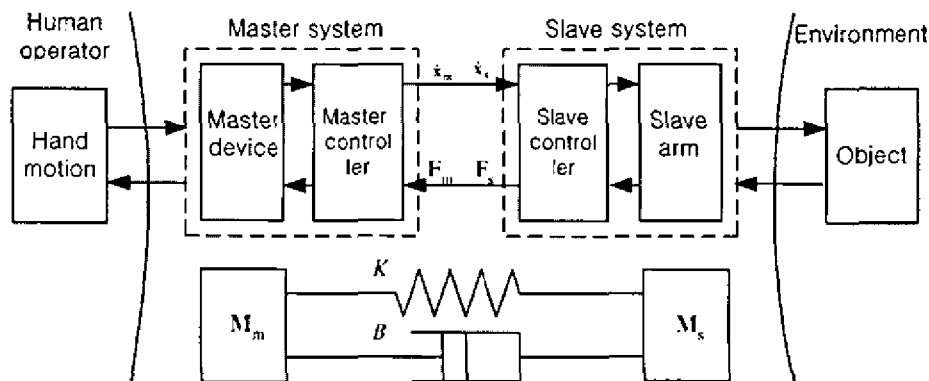

Fig. 6 Modeling of tele-manipulation system with network theory

case, the error is converted into an appropriate force signal and fed back to the master controller. The transmitted force signal is reproduced on the human operator by the master device, and it makes a constraint between the master and the slave in order to reduce the difference of motions. Finally, the slave follows up the motion of the master, and the master is bounded in some errors by force-feedback. If the two sides would interact via a well controlled path, it shows a behavior of a one degree of freedom mass spring damper system which has spring constant K and damping constant B , as shown in Fig. 6.

Traditional network theory focuses on the transmitted power to analyze a passivity and the stored energy in each node for checking a theoretical stability. In this research, discussion is limited to a practical usage of a teleoperated field robot system. Especially, compliance control, one of a useful semi-autonomous feature is focused on protecting its arm from unexpected contact when a time delay exists.

For actual integration of a haptic based field robot system, the scaled teleoperation would be performed, and also the compliance control can be adopted in the slave system as shown in Fig. 7.

A scaling process would be performed, because both nodes commonly have different workspaces in actual integration of system. Representing feedback force at the master system might be also magnified or reduced for minute sensation. Scaling the elements makes some differences in mathematical description in comparison with a normal form. It is denoted by

$$\begin{aligned} \dot{x}_s &= \rho_x \cdot \dot{x}_m \\ F_s &= \rho_F \cdot F_m \end{aligned} \tag{1}$$

where ρ_x and ρ_F are the scaling factors.

If the kinematics differs, tracking errors should occur between the endpoint of the haptic master and the slave. The kinematic relations between the joint and the Cartesian vectors for each system can be described by

$$\begin{aligned} \dot{x}_m &= J_m \cdot \dot{q}_m \\ \tau_m &= J_m^T \cdot F_m \end{aligned} \tag{2}$$

for master device and

$$x_a = J_s \cdot q_a \tag{3}$$

for slave arm, where J_m and J_s are the Jacobians of the systems. This approach has a problem that it would not be passive, because the force signal is no longer collocated with the corresponding velocity at the slave. The problem is less severe when the master and slave are closely connected with few and stiff dynamics in between. In this case the master and slave velocities are nearly identical. However, especially as it includes delays, this is no longer true and may show unexpected and unstable behavior. Practically, when an unexpected collision occurs, there is no way to protect the slave arm during the delay time that the contact force signal reaches the master. Most field robot systems adopt wireless communication, and several tens of milliseconds delay may occur. The goal of designing the controllers is not only to mimic the motion of the master but also to

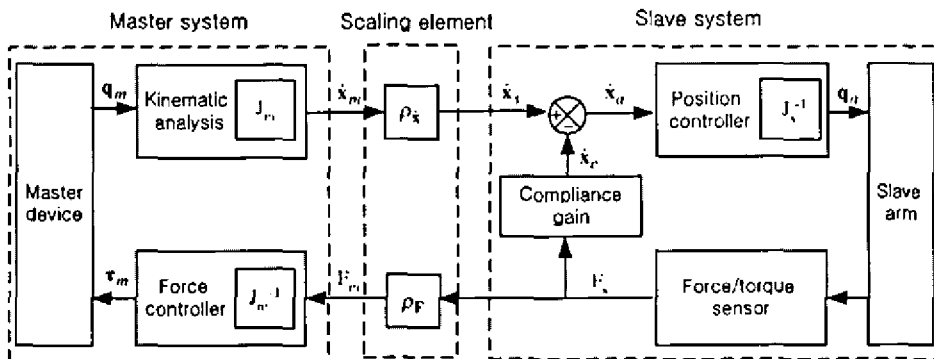

Fig. 7 Proposed tele-manipulation system with compliance control

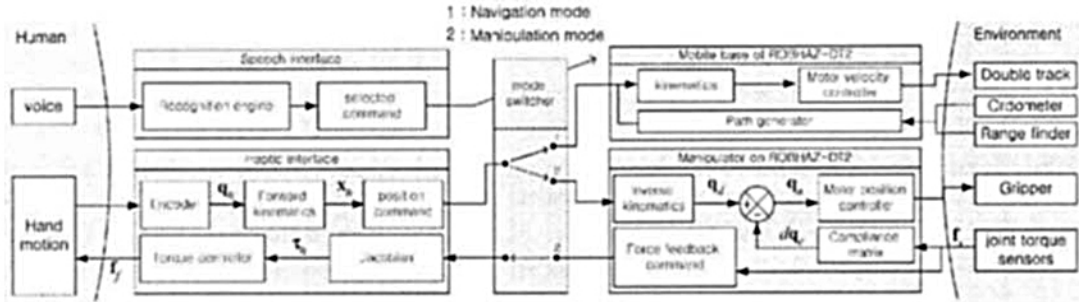

Fig. 8 Control schematic diagram for proposed system

protect its manipulator from an unexpected impact by collision.

For the problem, compliance control method is adopted to the slave as shown Fig. 7. The slave faithfully follows the scaled position \hat{x}_e by the position controller. However, when a contact occurs, the contact force is measured to calculate the displacement vector \hat{x}_c which presents adequate compliance with given factor K and B . The relation can be described by

$$F_s = K\hat{x}_c + B\dot{\hat{x}}_c \tag{4}$$

where the measured force F_s , the position and velocity displacement \hat{x}_c and $\dot{\hat{x}}_c$. The gains K and B are constant symmetric positive definite matrices. The adjusted position and velocity reference \hat{x}_e is used to control the manipulator. Finally, the contact force is regulated locally at the manipulator side. The measured force signal is also transmitted directly to the operator to inform the contact.

An actual system is fully integrated by using proposed multi-modal user interface, and the control schematic diagram is shown in Fig. 8.

4. Experiment

4.1 Tele-manipulation experiment

A simple experiment is conducted to verify the performance of the proposed system. As shown in Fig. 9, a user grips the handle of the haptic master and remotely controls the manipulator as a slave. There is a wall on the left side of the slave, thus the workspace would be bounded into an outside of the wall by a force feedback. In this experiment, the slave moves exactly the



Fig. 9 Integrated system for experiment of tele-manipulation

same as the motion of the user, because the scale for tele-manipulation is equal. No matter how kinematically different the master and the slave are, the motions of their end-effectors would match in the Cartesian space.

The sampling period of the controller for the master is one millisecond. However, the control period of the slave is quite slow in this system, because the slave's controller should gather not only the angular positions but also the torque data from six joints at each sample period. The controller for the slave takes 60 milliseconds for sensing and calculating the kinematics and the Jacobian. The master and the slave communicate with each other at every 30 milliseconds, to exchange the information of the position and the force. The transmission delay is practically enough to carry out a mission. The result of a tele-manipulation with respect to y shows in Fig. 10.

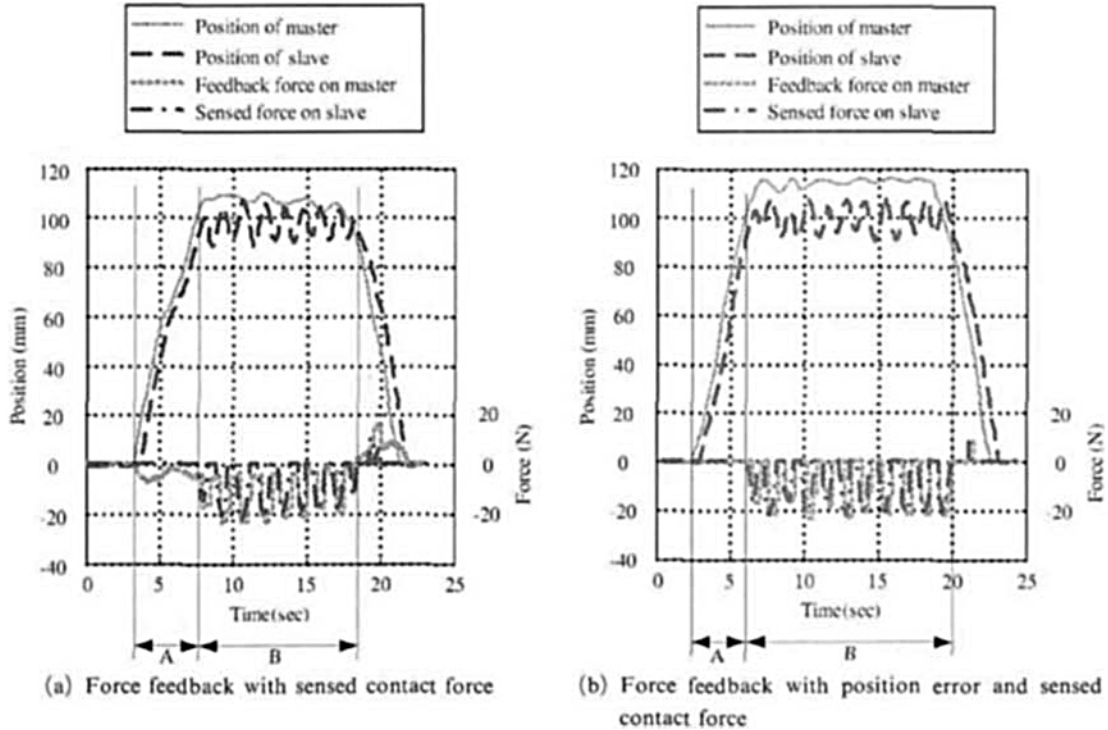

Fig. 10 Results of tele-manipulation experiment

In the situation A, the user starts to move and the slave follows with some delay. The measured communication delay is about 38 milliseconds, transferring the command data from master to slave. However, there would be an interval between the time when the slave receive a command and the time when the actual motion is detected. Even the command received, the system has an electrical and a mechanical rising time, and it brings an additional delay. The Fig. 10 shows that it takes about several hundreds milliseconds for the manipulator to start moving after the motion of the master.

The situation B shows the behaviors after bumping against the wall. The wall is located 100 mm up on the y axis. When the slave contacts to the wall, installed sensors detect the exerted force. The measured force transfers to the master and is used to generate a feedback force, and hence the user feels the reaction force on the wall. Generally, the bandwidth of the manipulator is lower than the master, because the slave has large inertia and high reduction. As a result,

the master moves much faster than the slave, and it may brings a problem when the manipulator contact to an obstacle. Even if the slave would sense the contact force on the wall, it takes time for the user to notice it with a feedback force.

In Fig. 10, the position of the master already intrudes into the virtual surface of the wall, when the slave touches the wall. At that time, the position of the master compels the slave to clash into the wall, and thus it can damage the slave. The slave's controller is designed to make a compliance to protect the slave from this situation. The slave shrinks its arm, when it touches the wall. The slave repeatedly bumps against the wall, and a small fluctuation occurs in this experiment, but it would settle down if the control period would be reduced.

Basically, it would be desired that the error between the master and the slave decreases. To decrease the error, a free motion of the master can be restricted by a feedback force. Not only the contact force but also the position error is used to provide a feedback force, as it shows

in Fig. 10(b). In the experiment, an error is measured, and a proportional force is exerted during the situation A and B. As a result, the user remotely feels the inertia of the slave, and the error is significantly reduced when the slave contacts to the wall.

4.2 EOD demonstration

As a result of full integration of the system, a simple EOD (explosive ordnance disposal) demonstration task was successfully executed in real environment, as shown in Fig. 11.

The demonstration setup for the EOD is artificially constructed for feasibility test. An operator remotely controls the robot by means of the proposed wearable multi-modal user interface. First, the user searches around by moving his head, as shown in Fig. 11(a), and the user points at a car door using the laser displacement sensor, then the distance and direction is announced by human language through the voice synthesis function. The user commands to approach by speech, and then the mobile base autonomously moves to assigned target as shown in Fig. 11(b). During the accessing motion, the operator could monitor the stereoscopic view transmitted from the pan-tilt stereo camera equipped in front of the

robot, and also auxiliary information, such as a velocity and an obstacle approach, is overlaid on the view. When the robot comes close to the door, it changes the operation mode to manipulate. The operator could easily change the control mode by saying the command to start manipulation. The robot recognizes the command and activates its manipulator. While the user moves his or her hand, the slave's manipulator mimics the motion of the operator, and opens the door using a tool as shown in Fig. 11(c). In manipulating the object placed in a car shown in Fig. 11(d), the operator could approach, grip and pick up an imitated bomb by feeling the contact forces via the haptic interface, and monitoring a fine view transmitted from the camera equipped at the arm's gripper as shown in Fig. 11(e). Then it moves to a safe place for the disposal.

5. Conclusions

In this research, wearable multi-modal user interface for a tele-manipulation of a field robot is proposed. A multi-modal interaction approach is adopted, and the user interface is comprised three components, such as visual interface, speech and auditory interface, haptic interface.

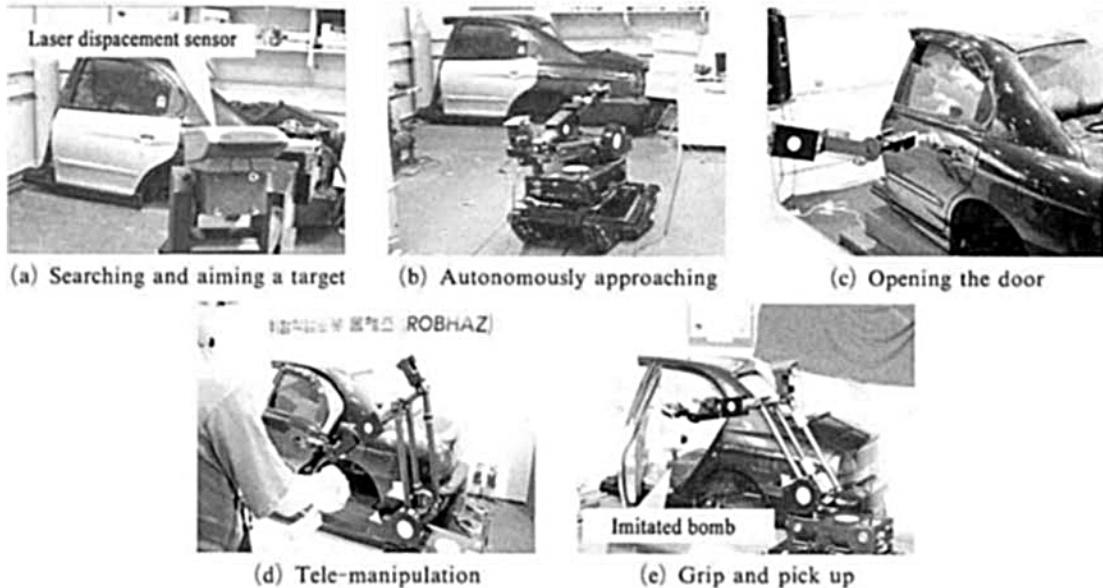

Fig. 11 Demonstration of explosive ordnance disposal

In this work, a pre-commercialized field robot prototype is integrated to examine the proposed user interface, and the control method is presented in detail. The features in the work are summarized as follows:

- (1) Whole system is packed as a wearable backpack.
- (2) The operator makes the command by speech and a motion.
- (3) All nonhaptic information is shown on HMD as a unified scene
- (4) The haptic master can simultaneously teleoperate and get feedback from the mobile and manipulator system.

An EOD experiment is performed to verify the usefulness of the proposed system, and its practical effectiveness has been successfully tested.

References

- MacGuire Fritsch, P., Steil, J. J., Rothling, F., Fink, G. A., Washsmuth, S., Sagerer, G. and Ritter, H., 2002, "Multi-modal Human-machine Communication for Instructing Robot Grasping Tasks for Instructing Robot Grasping Tasks," Proc. of IEEE International Conference on Intelligence Robotics and Systems.
- Nonami, K. and Shimoi, N., 2000, "Development of Teleoperated Six-legged Walking Robot for Mine Detection and Mapping of Mine Field," Proc. of the 2000 IEEE/RSJ International Conference on Intelligent Robots and Systems, pp. 775~779.
- Penny, M. D., Cotter, S., Beagley, N., Smith, N. and Wong, K., 2002, "A Comparison Study of Operator Performance with Three Controllers for a Remotely Operated Vehicle," IARP workshop on robots for humanitarian demining 87-92.
- Ryu, D. S., Kang, S. C., Kim, M. S. and Song, J. B., 2004, "Multi-modal User Interface for Teleoperation of ROBHAZ-DT2 Field Robot System," Proc. of IEEE International Conference on Intelligence Robotics and Systems.
- Saeed Shiry Ghidary, Yasushi Nakata, Hiroshi saito, Motofumi Hattori and Toshi Takamori, 2001, "Multi-modal Human Robot Interaction for Map Generation," Proc. of IEEE International Conference on Intelligence Robotics and Systems.
- Soshi Iba, Christian Paredis, J. J. and Pradeep Khosla, K., 2002, "Interactive Multimodal Robot Programming," Proc. of IEEE International Conference on Robotics and Automation.
- Sungchul Kang, Chanhyun Cho, Jonghwa Lee, Dongseok Ryu, Changwoo Park, Kyung-Chul Shin and Munsang Kim, 2003, "ROBHAZ-DT2 Design and Integration of Passive Double Tracked Mobile Manipulator System for Explosive Ordnance Disposal," Proceeding of the IEEE/RSJ Intl.Conference on Intelligent Robots and Systems, pp. 2624~2629.
- Takahashi, Y. and Masuda, I., 1992, "A Visual Interface for Security Robots," *International Workshop on Robot and Human Communication*, pp. 123~128
- <http://www.highcomsecurity.com/>
<http://www.irobot.com/>
<http://www.remotec-andros.com/>